



# EZYTrigger™

TM

Active Trigger units for firing Power Thyristors



## Sales and Distribution Europe

Tel.: +49 (0)2432 49677  
Mail: [info@amelectronic.de](mailto:info@amelectronic.de)

Fax: +49 (0)2432 49656  
[www.amelectronic.de](http://www.amelectronic.de)



Andreas Müller Electronic



# EZYTrigger™

Active Trigger units for firing Power Thyristors



- Trigger control for thyristors by logic circuit output signals from microcontrollers, microprocessors, CPLDs or FPGAs
- Optical control for any type and size of thyristors, including amplifying-gate devices
- A high electrical isolation is warranted due to opto-coupler input circuit or fibre-optic cable devices
- The recommended control current for the trigger signal is 12mA
- The standard units are intended for mains voltages of 100 – 690 Vrms
- The high voltage units are intended for mains voltages of 1250 and 2500Vrms
- The EZYTrigger units are working under all possible loads also for large inductive loads
- There is no extra power supply needed, because the gate-current derives from the thyristor anode
- The integrated gate-current control circuit allows twisted gate leads up to 1m
- The compact design allows space saving layout of the PCBs
- The EZYTriggers have a high interference resistance under difficult operation conditions
- The AT410 series replaces two pulse transformers with single secondary windings  
and the AT413, AT414 or the AT416 can replace a single puls transformer
- All components and parts used in these units have been certified by their manufacturers as RoHS Compliant. Epoxy filler is RoHS Compliant (2011/65/EU) and UL Approval meets UL94 V-0. The Optocoupler is approved for UL1577 File No. E52744 System Code H or J, Double Protection and DIN EN 60747-5-2 (VDE0884), RoHS 2002/96/EC and WEEE (2002/96/EC). No warranty is given for the accuracy of information stated by the respective manufacturers.

for further information please contact:

Andreas Müller Electronic GmbH    Armin Jantschik    a.jantschik@amelectronic.de

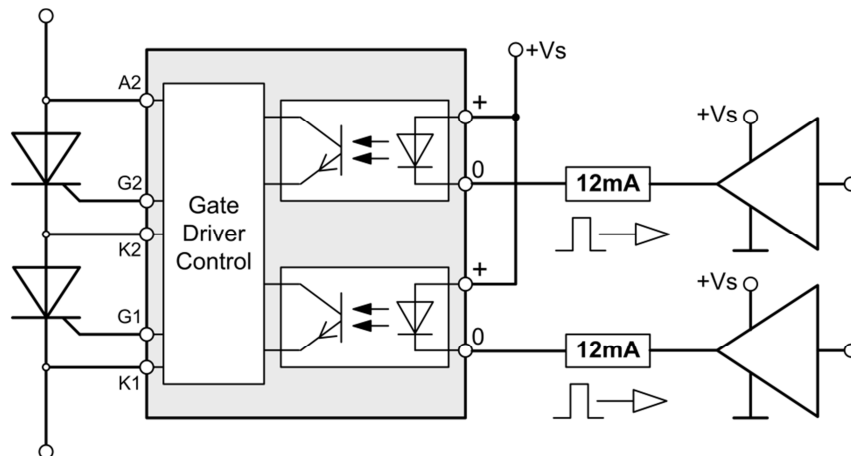

- Upon application of the control current, the thyristor receives a fast-rising gate current which is fully maintained until the anode voltage of the thyristor collapses below the threshold voltage after it is triggered
- This method of operation accounts for the low power dissipation of the trigger unit
- The thyristor will be reliably triggered with an 8 - 12mA signal and a small turn-on delay of approximately 25µs
- Current flow is initiated by an opto-coupler which provides the electrical isolation
- By maintaining the gate current long enough to reach the latching current the system can be safely used in applications with large inductive loads
- The anode voltage of the thyristor must be at least 14V before the gate current reaches 200mA.

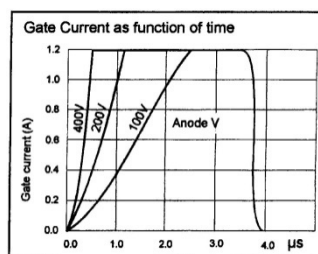
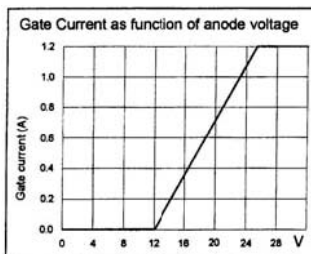

- The full gate current is maintained until the thyristor triggers and is terminated when the anode voltage goes below 14V
- The rise-time of the gate current is approximately proportional to the supply voltage and is typically 2A/µs
- The full forward voltage dv/dt can only be re-applied 100µs after removing the trigger signal from the control terminals
- The envelope of the voltage across the thyristor can have any desired shape provided the rms value is below the nominal voltage  $V_m$  and the peak value does not exceed peak voltage  $V_p$

## AT 410

Line voltage 100 – 690V<sub>rms</sub>

### Applications:

- Controlled Rectifiers
- AC Controllers
- DC Motor Control

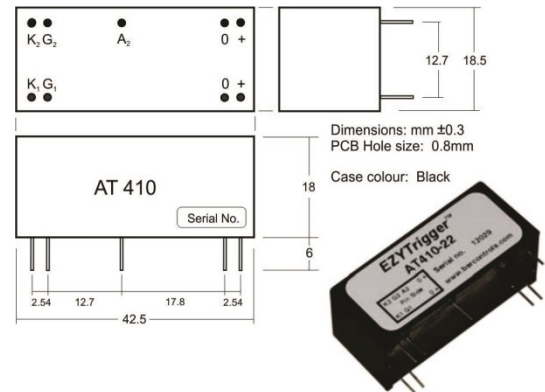
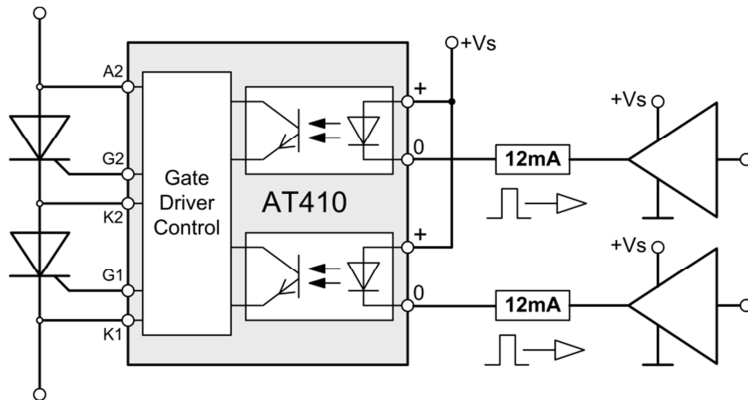

### Absolute Maximum Ratings

EZYTrigger Type

Parameter	Symbol	AT410 - 12	AT410 - 22
Peak voltage – positive and negative	V <sub>p</sub>	1200 V	2200 V
Nominal mains voltage	V <sub>m</sub>	400 V	690 V
Continuous DC voltage	V <sub>=</sub>	400 V	690 V
Turn-on delay for gate current >1A	t <sub>gd</sub>	5 μs	5 μs
Input-Output Isolation	V <sub>i</sub>	6000Vrms 50Hz 1min VDE0884	
Input-Output transient immunity	(dv/dt) <sub>c</sub>	5000 V/μs	
Device transient immunity	(dv/dt) <sub>d</sub>	2000 V/μs	
Ambient temperature range	T <sub>a</sub>	-20°C to +85°C	

### Technical Data at 25°C

200mA gate current threshold	V <sub>gtl</sub>	10 V	16 V
1.8A gate current threshold	V <sub>gth</sub>	24 V	36 V
Gate current rise time ⇒ anode voltage	⇒ 100V (di/dt) <sub>g</sub>	2.5 A/μs	1.2 A/μs
	⇒ 200V (di/dt) <sub>g</sub>	3 A/μs	2 A/μs
	⇒ 400V (di/dt) <sub>g</sub>	4 A/μs	2.5 A/μs
	⇒ 800V (di/dt) <sub>g</sub>	6 A/μs	3 A/μs
	⇒ 1200V (di/dt) <sub>g</sub>	-	4 A/μs
Peak gate current	I <sub>p</sub>	1.8 A	1.8 A
Anode-cathode current at peak voltage V <sub>p</sub>	I <sub>n</sub>	4.4 mA	5.1 mA
Maximum off-state gate current	I <sub>o</sub>	2 μA	2 μA
Minimum control current	I <sub>cm</sub>	7 mA	7 mA
Recommended control current	I <sub>c</sub>	12 mA	12 mA
Control input voltage drop at 12mA gate current	V <sub>in</sub>	Typ 1.2 < 1.5V	Typ 1.2 < 1.5V
Maximum reverse control input voltage	V <sub>inr</sub>	6 V	6 V
Turn-on delay time at I <sub>control</sub> = 12mA	t <sub>di</sub>	25 μs	25 μs

## AT 411

Line voltage 100 – 690V<sub>rms</sub>

### Applications:

- Low cost AC Controllers

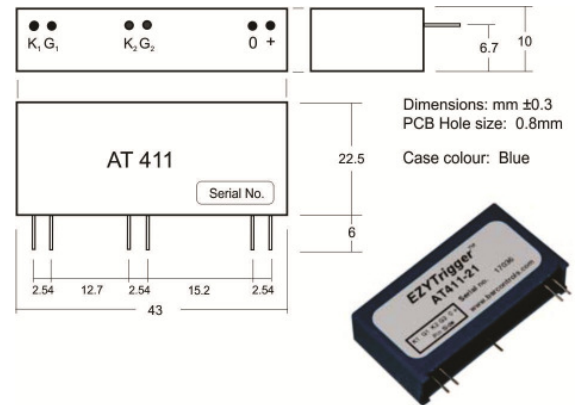
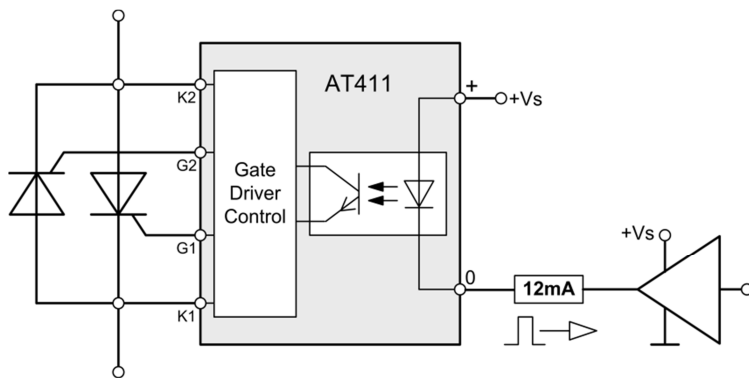

### Absolute Maximum Ratings

### EZYTrigger Type

Parameter	Symbol	AT411 - 12	AT411 - 21
Peak voltage – positive and negative	V <sub>p</sub>	1200 V	2100 V
Nominal mains voltage	V <sub>m</sub>	400 V	690 V
Continuous DC voltage	V <sub>=</sub>	400 V	690 V
Turn-on delay for gate current >1A	t <sub>gd</sub>	5 μs	5 μs
Input-Output Isolation	V <sub>i</sub>	6000Vrms 50Hz 1min VDE0884	
Input-Output transient immunity	(dv/dt) <sub>c</sub>	5000 V/μs	
Device transient immunity	(dv/dt) <sub>d</sub>	2000 V/μs	
Ambient temperature range	T <sub>a</sub>	-20°C to +85°C	

### Technical Data at 25°C

200mA gate current threshold	V <sub>gtl</sub>	10 V	16 V
1.8A gate current threshold	V <sub>gth</sub>	24 V	36 V
Gate current rise time ⇒ anode voltage	⇒ 100V (di/dt) <sub>g</sub>	2.5 A/μs	1.2 A/μs
	⇒ 200V (di/dt) <sub>g</sub>	3 A/μs	2 A/μs
	⇒ 400V (di/dt) <sub>g</sub>	4 A/μs	2.5 A/μs
	⇒ 800V (di/dt) <sub>g</sub>	6 A/μs	3 A/μs
	⇒ 1200V (di/dt) <sub>g</sub>	-	4 A/μs
Peak gate current	I <sub>p</sub>	1.8 A	1.8 A
Anode-cathoden current at peak voltage V <sub>p</sub>	I <sub>n</sub>	4.4 mA	5.1 mA
Maximum off-state gate current	I <sub>o</sub>	2 μA	2 μA
Minimum control current	I <sub>cm</sub>	7 mA	7 mA
Recommended control current	I <sub>c</sub>	12 mA	12 mA
Control input voltage drop at 12mA gate current	V <sub>in</sub>	Typ 1.2 < 1.5V	Typ 1.2 < 1.5V
Maximum reverse control input voltage	V <sub>inr</sub>	6 V	6 V
Turn-on delay time at I <sub>control</sub> = 12mA	t <sub>di</sub>	25 μs	25 μs

## AT 412

Line voltage 100 – 690V<sub>rms</sub>

### Applications:

- Zero-cross switching applications
- For 3-phase solid-state operation the control terminals are wired in series

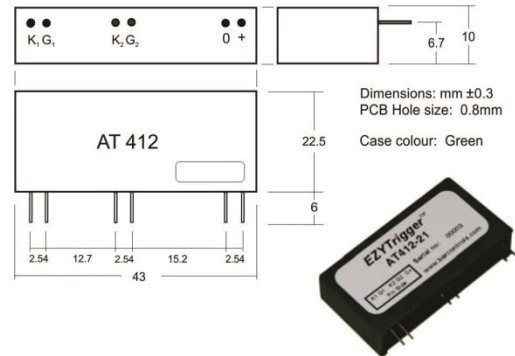
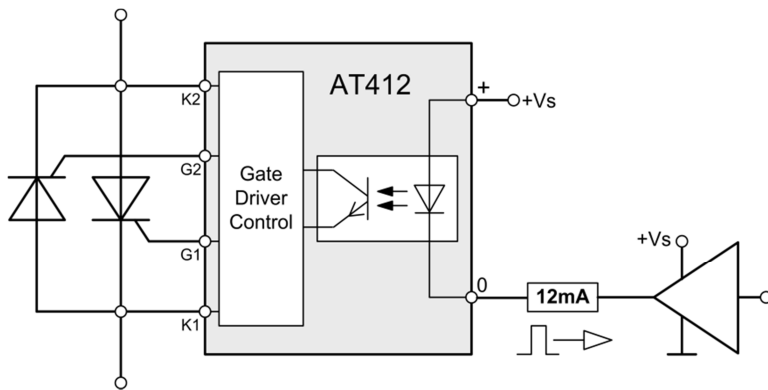

### Absolute Maximum Ratings

EZYTrigger Type

Parameter	Symbol	AT412 - 12	AT412 - 21
Peak voltage – positive and negative	V <sub>p</sub>	1200 V	2100 V
Nominal mains voltage	V <sub>m</sub>	400 V	690 V
Continuous DC voltage	V <sub>=</sub>	400 V	690 V
Turn-on delay for gate current >1A	t <sub>gd</sub>	5 μs	5 μs
Input-Output Isolation	V <sub>i</sub>	6000Vrms 50Hz 1min VDE0884	
Input-Output transient immunity	(dv/dt) <sub>c</sub>	5000 V/μs	
Device transient immunity	(dv/dt) <sub>d</sub>	2000 V/μs	
Ambient temperature range	T <sub>a</sub>	-20°C to +85°C	

### Technical Data at 25°C

200mA gate current threshold	V <sub>gtl</sub>	10 V	16 V
1.8A gate current threshold	V <sub>gth</sub>	24 V	36 V
Gate current rise time ⇒ anode voltage	(di/dt) <sub>g</sub>	2.5 A/μs	1.2 A/μs
⇒ 200V	(di/dt) <sub>g</sub>	3 A/μs	2 A/μs
⇒ 400V	(di/dt) <sub>g</sub>	4 A/μs	2.5 A/μs
⇒ 800V	(di/dt) <sub>g</sub>	6 A/μs	3 A/μs
⇒ 1200V	(di/dt) <sub>g</sub>	-	4 A/μs
Peak gate current	I <sub>p</sub>	1.8 A	1.8 A
Anode-cathoden current at peak voltage V <sub>p</sub>	I <sub>n</sub>	4.4 mA	5.1 mA
Maximum off-state gate current	I <sub>o</sub>	< 40 μA	< 40 μA
Minimum control current	I <sub>cm</sub>	7 mA	7 mA
Recommended control current	I <sub>c</sub>	12 mA	12 mA
Control input voltage drop at 12mA gate current	V <sub>in</sub>	Typ 1.2 < 1.5V	Typ 1.2 < 1.5V
Maximum reverse control input voltage	V <sub>inr</sub>	6 V	6 V
Turn-on delay time at I <sub>control</sub> = 12mA	t <sub>di</sub>	25 μs	25 μs
Zero-crossing threshold	V <sub>zt</sub>	<20 V	<20 V

## AT 413

Line voltage 100 – 690V<sub>rms</sub>

### Applications:

- Single thyristor logic control trigger applications

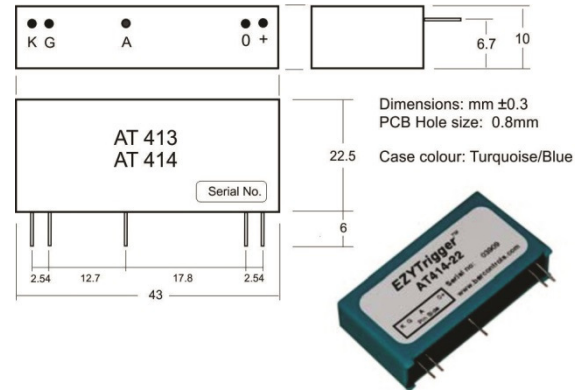
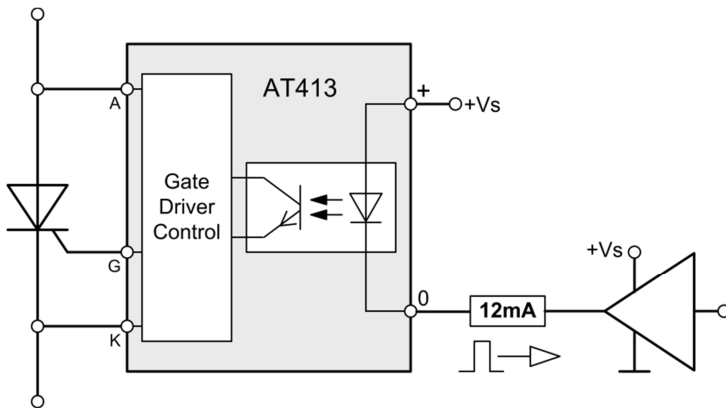

### Absolute Maximum Ratings

EZYTrigger Type

Parameter	Symbol	AT413 – 22
Peak voltage – positive and negative	V <sub>p</sub>	2200 V
Nominal mains voltage	V <sub>m</sub>	690 V
Continuous DC voltage	V <sub>=</sub>	690 V
Turn-on delay for gate current >1A	t <sub>gd</sub>	5 μs
Input-Output isolation	V <sub>i</sub>	6000Vrms 50Hz 1min VDE0884
Input-Output transient immunity	(dv/dt) <sub>c</sub>	5000 V/μs
Device transient immunity	(dv/dt) <sub>d</sub>	2000 V/μs
Ambient temperature range	T <sub>a</sub>	-20°C to +85°C

### Technical Data at 25°C

200mA gate current threshold	V <sub>gtl</sub>	16 V
1.8A gate current threshold	V <sub>gth</sub>	36 V
Gate current rise time ⇒ anode voltage	⇒ 100V (di/dt) <sub>g</sub>	1.2 A/μs
	⇒ 200V (di/dt) <sub>g</sub>	2 A/μs
	⇒ 400V (di/dt) <sub>g</sub>	2.5 A/μs
	⇒ 800V (di/dt) <sub>g</sub>	3 A/μs
	⇒ 1200V (di/dt) <sub>g</sub>	4 A/μs
Peak gate current	I <sub>p</sub>	1.8 A
Anode-cathode current at peak voltage V <sub>p</sub>	I <sub>n</sub>	5.1 mA
Maximum off-state gate current	I <sub>o</sub>	2 μA
Minimum control current	I <sub>cm</sub>	7 mA
Recommended control current	I <sub>c</sub>	12 mA
Control input voltage drop at 12mA gate current	V <sub>in</sub>	Typ 1.2 < 1.5V
Maximum reverse control input voltage	V <sub>inr</sub>	6 V
Turn-on delay time at I <sub>control</sub> = 12mA	t <sub>di</sub>	25 μs

## AT 414

Line voltage 100 – 690V<sub>rms</sub>

### Applications:

- Triggersignal input designed for optical receiver device
- Optical control of a single thyristor with up to 25m fibre-optic cable
- Optical control of any thyristor type including also with amplifying gate

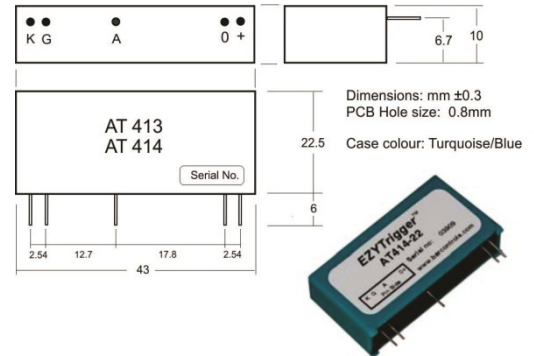
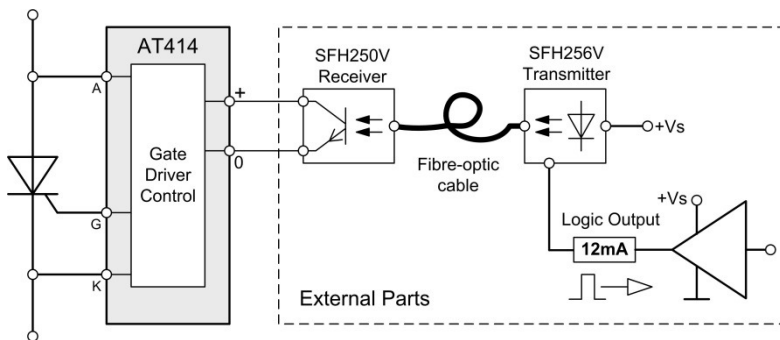

### Absolute Maximum Ratings

EZYTrigger Type

Parameter	Symbol	AT414 – 22
Peak voltage – positive and negative	V <sub>p</sub>	2200 V
Nominal mains voltage	V <sub>m</sub>	690 V
Continuous DC voltage	V <sub>=</sub>	690 V
Turn-on delay for gate current >1A	t <sub>gd</sub>	5 μs
Input-Output isolation	V <sub>i</sub>	6000Vrms 50Hz 1min VDE0884
Input-Output transient immunity	(dv/dt) <sub>c</sub>	5000 V/μs
Device transient immunity	(dv/dt) <sub>d</sub>	2000 V/μs
Ambient temperature range	T <sub>a</sub>	-20°C to +85°C

### Technical Data at 25°C

200mA gate current threshold	V <sub>gtl</sub>	16 V
1.8A gate current threshold	V <sub>gth</sub>	36 V
Gate current rise time ⇒ anode voltage	⇒ 100V (di/dt) <sub>g</sub>	1.2 A/μs
	⇒ 200V (di/dt) <sub>g</sub>	2 A/μs
	⇒ 400V (di/dt) <sub>g</sub>	2.5 A/μs
	⇒ 800V (di/dt) <sub>g</sub>	3 A/μs
	⇒ 1200V (di/dt) <sub>g</sub>	4 A/μs
Peak gate current	I <sub>p</sub>	1.8 A
Anode-cathoden current at peak voltage V <sub>p</sub>	I <sub>n</sub>	5.8 mA
Maximum off-state gate current	I <sub>o</sub>	2 μA
Minimum control current	I <sub>cm</sub>	7 mA
Recommended control current	I <sub>c</sub>	12 mA
Control input voltage drop at 12mA gate current	V <sub>in</sub>	Typ 1.2 < 1.5V
Maximum reverse control input voltage	V <sub>inr</sub>	6 V
Turn-on delay time at I <sub>control</sub> = 12mA	t <sub>di</sub>	25 μs



## BT 414

Line voltage 100 – 690V<sub>rms</sub>

### Applications:

- Ready for connection PCB Assembly with AT414-22 EZYTrigger and optical fibre receiver device
- Optical control of a single thyristor with up to 25m fibre-optic cable
- Optical control of any thyristor type including amplifying gate devices

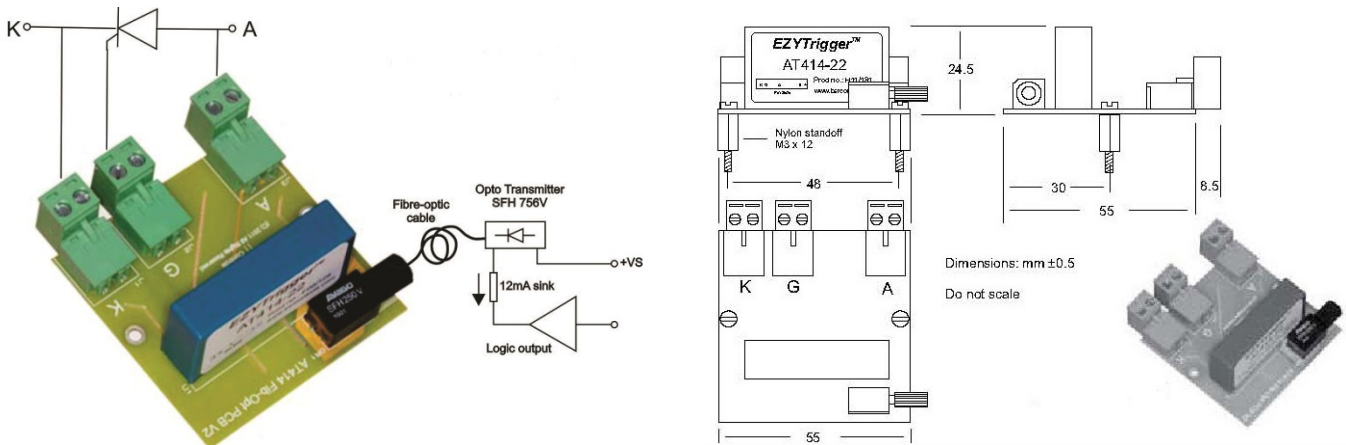

### Absolute Maximum Ratings

### EZYTrigger Type

Parameter	Symbol	AT414 – 22	
Peak voltage – positive and negative	V <sub>p</sub>	2200 V	
Nominal mains voltage	V <sub>m</sub>	690 V	
Continuous DC voltage	V <sub>=</sub>	690 V	
Turn-on delay for gate current >1A	t <sub>gd</sub>	5 μs	
Input-Output isolation	V <sub>i</sub>	6000Vrms 50Hz 1min VDE0884	
Input-Output transient immunity	(dv/dt) <sub>c</sub>	5000 V/μs	
Device transient immunity	(dv/dt) <sub>d</sub>	2000 V/μs	
Ambient temperature range	T <sub>a</sub>	-20°C to +85°C	

### Technical Data at 25°C

200mA gate current threshold	V <sub>gtl</sub>	16 V
1.8A gate current threshold	V <sub>gth</sub>	36 V
Gate current rise time ⇒ anode voltage	⇒ 100V (di/dt) <sub>g</sub>	1.2 A/μs
	⇒ 200V (di/dt) <sub>g</sub>	2 A/μs
	⇒ 400V (di/dt) <sub>g</sub>	2.5 A/μs
	⇒ 800V (di/dt) <sub>g</sub>	3 A/μs
	⇒ 1200V (di/dt) <sub>g</sub>	4 A/μs
Peak gate current	I <sub>p</sub>	1.8 A
Anode-cathode current at peak voltage V <sub>p</sub>	I <sub>n</sub>	5.8 mA
Maximum off-state gate current	I <sub>o</sub>	2 μA
Minimum control current	I <sub>cm</sub>	7 mA
Recommended control current	I <sub>c</sub>	12 mA
Control input voltage drop at 12mA gate current	V <sub>in</sub>	Typ 1.2 < 1.5V
Maximum reverse control input voltage	V <sub>inr</sub>	6 V
Turn-on delay time at I <sub>control</sub> = 12mA	t <sub>di</sub>	25 μs

## AT 416

Line voltage 1250 and 2500V<sub>rms</sub>

### Applications:

- The trigger signal 10mA converts any high-voltage thyristors into optically controlled devices
- Required gate current is derived from the anode of the thyristor via a controlled current source of 2.5A
- There is no need for an additional isolated power source for gate drive

- ⇒ The unit should be mounted in close proximity to the thyristor with leads as short as possible
- ⇒ If the unit is mounted directly on the heatsink, it is recommended that it be positioned on the heatsink with the same potential as the cathode of the thyristor.
- ⇒ This minimizes interference from fast-rising high-voltage spikes from the mains
- ⇒ For the same reason other leads should be kept away from the body of the trigger unit.
- ⇒ It is recommended that the minimum 5mA control current be increased to 10mA to allow for ageing of the optical components
- ⇒ If simultaneous triggering is required for a number of series-connected thyristors, it is advisable to use pulse shaping for the transmitter input.
- ⇒ An RC network with a time constant of 10µs can be used to create an initial current of 20mA, decaying to 10mA.
- ⇒ It is also advisable to maintain the control signal during the required conduction period of the thyristor.

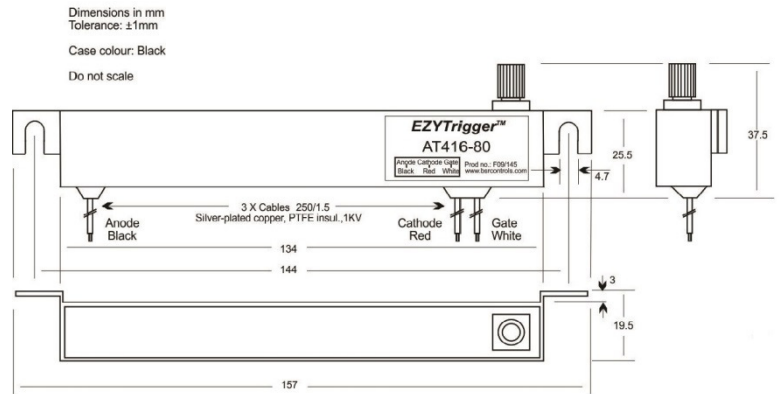
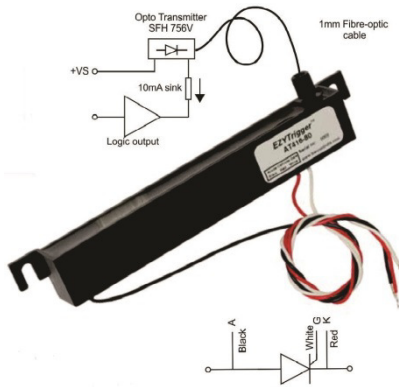

### Absolute Maximum Ratings

Parameter	Symbol	EZYTrigger Type	
		AT416 – 40	AT416 – 80
Peak voltage – positive and negative	V <sub>p</sub>	4000 V	8000 V
Nominal mains voltage	V <sub>m</sub>	1250 V	2500 V
Continuous DC voltage	V <sub>=</sub>	2500 V	2500 V
Thyristor turn-on time ( t <sub>gate-delay</sub> + t <sub>r</sub> )	t <sub>on</sub>	6 µs	6 µs
Anode-Cathode transient immunity	(dv/dt) <sub>c</sub>	5000 V/µs	
Ambient temperature range	T <sub>a</sub>	-20°C to +85°C	

### Technical Data at 25°C

500 mA Gate current threshold	V <sub>gtl</sub>	40 V	40 V
2.5 A Gate current threshold	V <sub>gth</sub>	90 V	140 V
Gate current rise time ⇒ Anode voltage ⇒ 800V	(di/dt) <sub>g</sub>	1.2 A/µs	1.2 A/µs
Peak gate current	I <sub>p</sub>	2.5 A	2.5 A
Anode-cathode current at V <sub>p</sub> and I <sub>g</sub> = 0	I <sub>n</sub>	4 mA	4.6 mA
Maximum off-state gate current	I <sub>o</sub>	2 µA	2 µA
Minimum control current (SFH756 Transm./ 1m fibre)	I <sub>cm</sub>	5 mA	5 mA
Recommended control current (SFH756 Transm./ 1m fibre)	I <sub>c</sub>	10 mA	10 mA
Control input voltage drop at 10mA	V <sub>in</sub>	Typ 1.2 < 1.5V	Typ 1.2 < 1.5V
Maximum reverse control input voltage	V <sub>inr</sub>	6 V	6 V
Turn-on delay time at I <sub>control</sub> = 10mA	t <sub>di</sub>	7 µs	7 µs



The principle of the EZYTrigger™ was developed and first employed by Bernhard Rudert in the mid-1970s for 25 – 100T cranes. At that time the main customer for the product was the South African electricity utility (Eskom) which required reliable speed control for installing and maintaining their turbines. The EZYTrigger™ was also then supplied to the German crane manufacturer, Demag. By the 80's Woolf Cranes was using the units for 10 – 25T cranes and later for 180T ladle cranes. The biggest ladle crane to date using the EZYTrigger™ is 600T. The units are used extensively in harsh and hazardous environments in the iron and steel industry, harbours and mines where the device had not only to stand up to high temperatures, but continuous high mains voltage spikes which were the cause of pulse transformer breakdown. The scope of applications has grown and now encompasses industries across the power spectrum wherever thyristors are used.

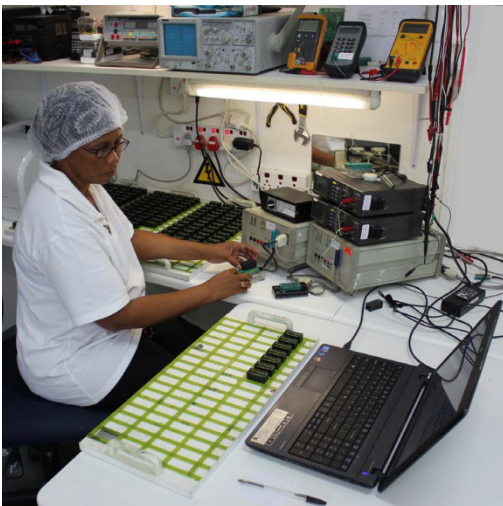

The original open board construction went through a number of design cycles to improve performance, reliability and ease of use.

Today, the EZYTrigger™ is a fully encapsulated, stand-alone component which requires only input information from a microprocessor, CPLD or FPGA source and connection to the gate and cathode of the thyristor, thus eliminating the need for an extra power supply and pulse transformers.

Every single unit produced is tested twice times in the process: once before encapsulation and once after encapsulation.

Test parameters of the EZYTrigger™ are such that similar conditions would rarely be encountered in the field, a fact which is reflected in the zero failure rate which has been achieved over the past decades of use. Any unit which drops out in either of these test programs, is subjected to a rigorous investigation to preclude a recurrence of the cause.

Our manufacturing philosophy is simple:

anything which can go wrong, must go wrong in the factory and not in the customer's equipment.

Our production staff live this philosophy and take great pride in the quality of their efforts.

[sales@bsrcontrols.com](mailto:sales@bsrcontrols.com) / [www.bsrcontrols.com](http://www.bsrcontrols.com)